

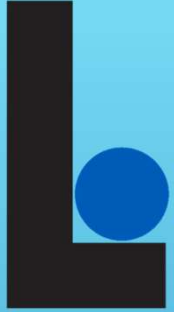

Liberda Antriebstechnik



Productline – Classic Line

- Motor can be located in the upper or vertical profile
 - Vertical and horizontal toothed belt possible
 - Electronic located in the vertical profile or control cabinet
-
- 
- 3 sizes for different sash weights
 - Size 1 – up to 350 kg
 - Size 2 – up to 700 kg
 - Size 3 – up to 1200 kg
 - Mechanics tested for a 30-year service life

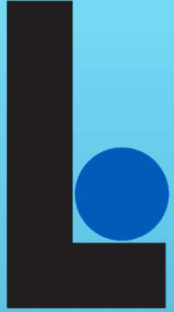

Productline – Classic Line

- We can cover a wide range of applications and installation cases with our system
- We customize our solution to your profile
- We manufacture our control system ourselves
- We develop new solutions on customer request





Overview of the system

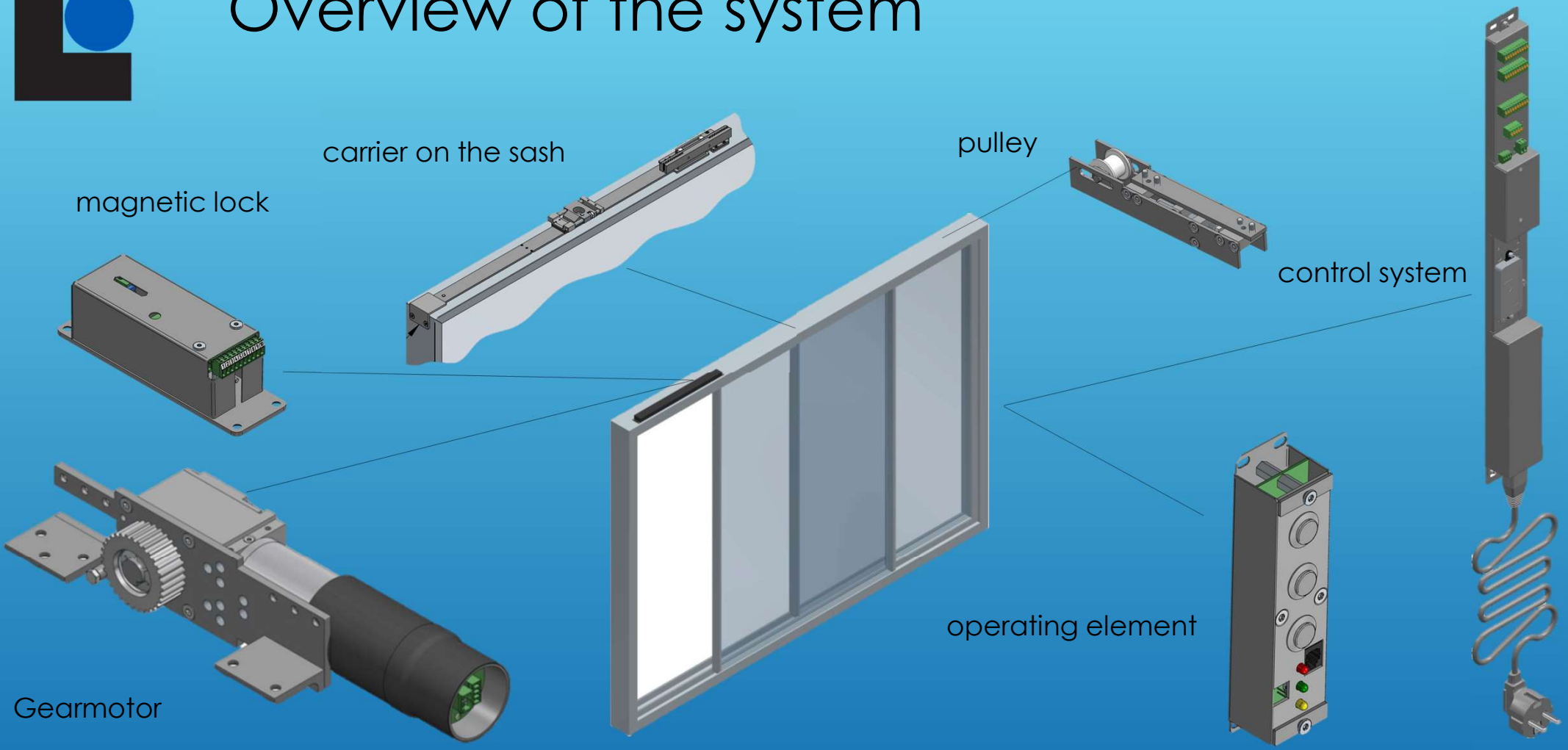



Productline - Classicline

- Machining required for installation in the upper profile

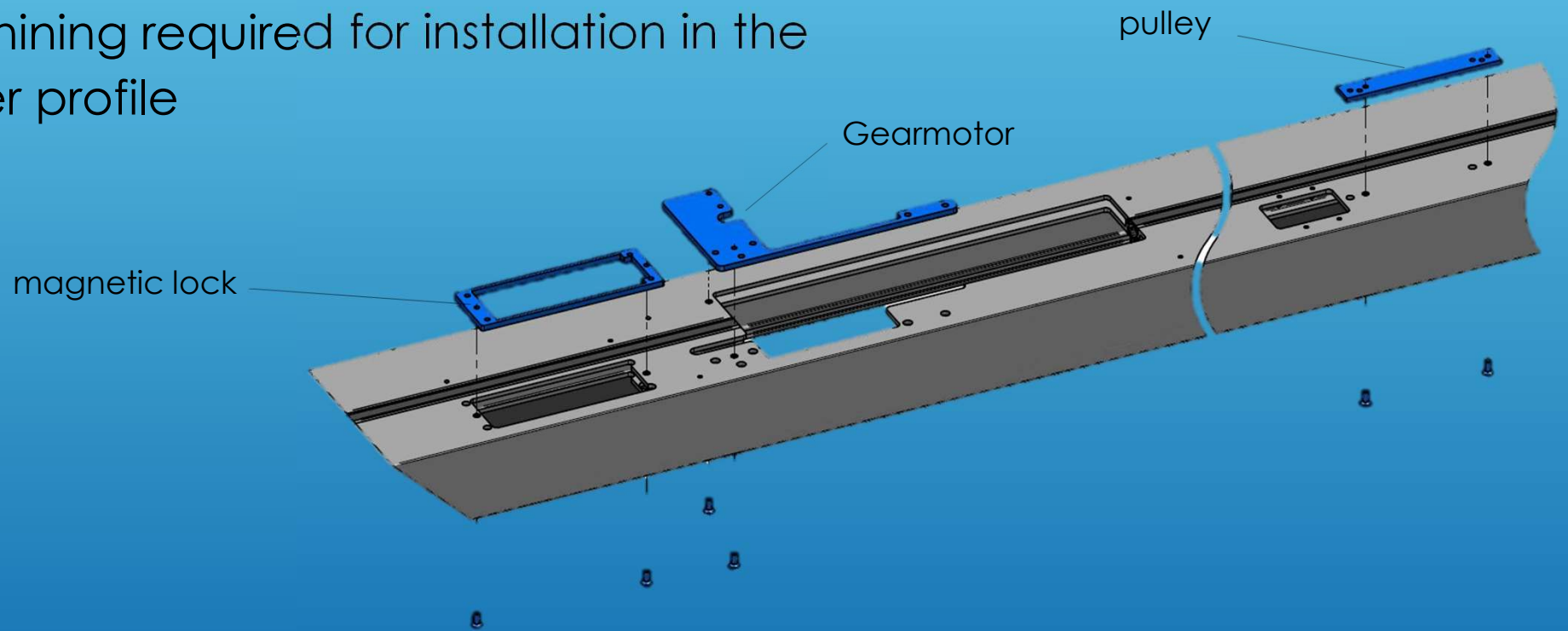

Productline - Classicline

- Space consumption of the motor in the upper profile

Depends on the used system (vertical or horizontal tooth belt)

- X approx - 65mm
- Z approx - 27mm

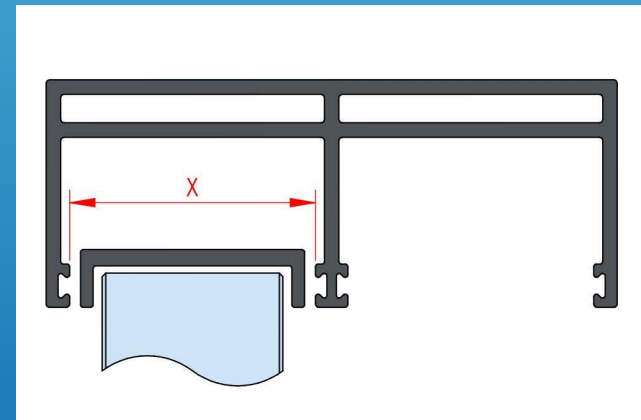
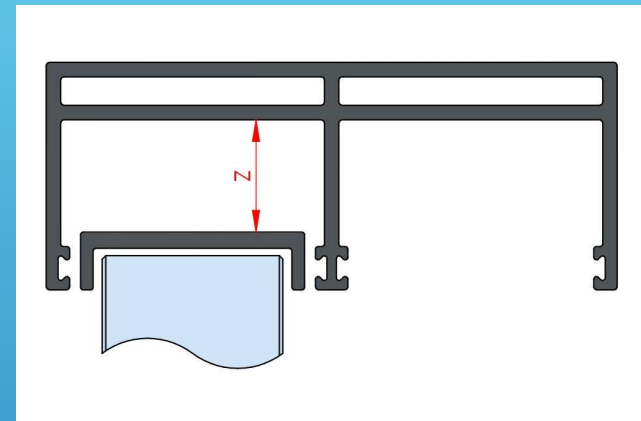

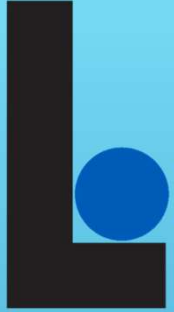

Productline – Classic Line

- Also available from us
 - Radio transmitter
 - Remote maintenance options
 - Home automation system connection
 - Wifi option for the control system
 - Precisely fitting mounting brackets and fittings
 - Matching toothed belt
 - Prefabricated set articles
 - System prepared for plug & play

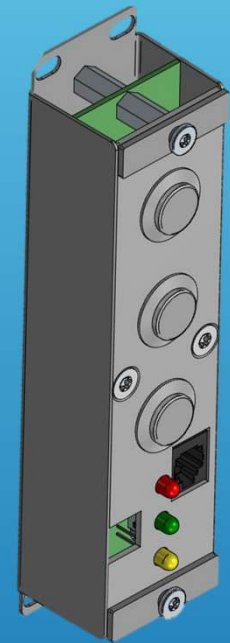

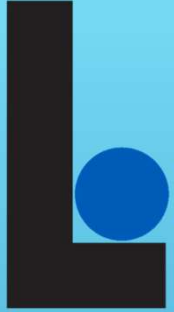

Liberda Antriebstechnik

