

Liberda Antriebstechnik

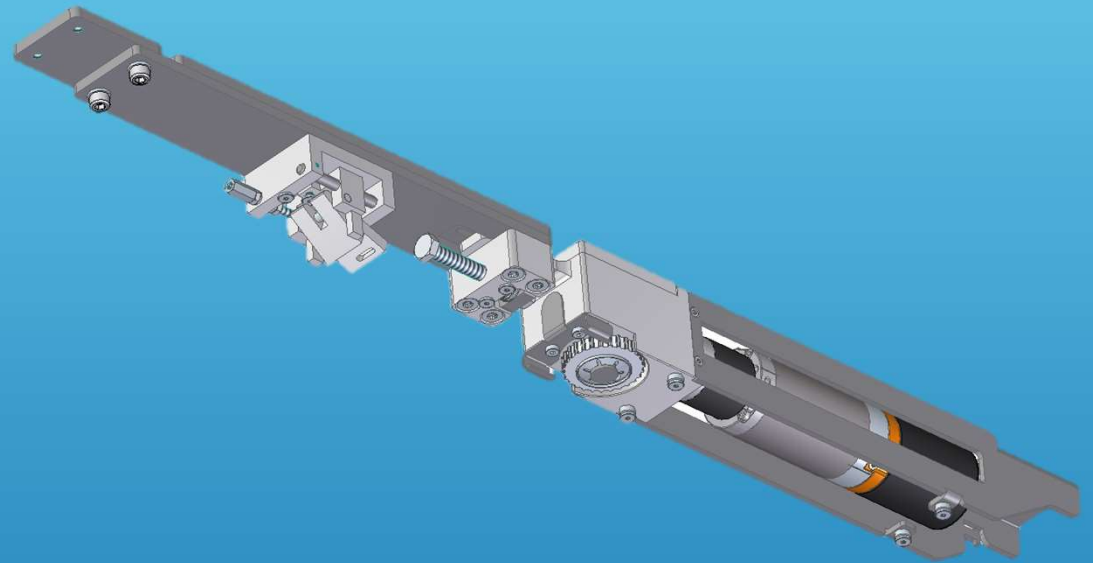

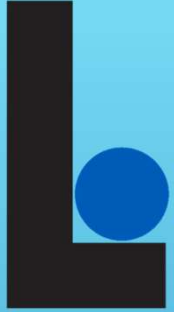

New Product – Slim Line

- Motor and mechanics are located in the upper profile
- Control unit is installed in the vertical profile



- Space requirement in the upper profile reduced
- Pulling force up to 180N
- Mechanical locking included
- Mechanics tested for a 30-year service life
- BLDC drive - door slides easily
- fits into a rail

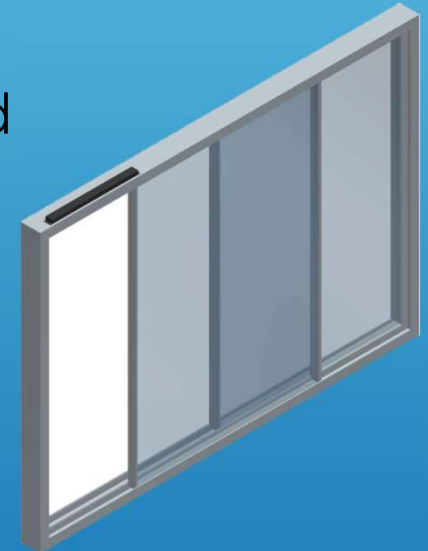

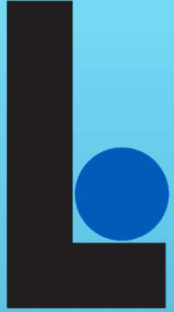

New Product – Slim Line

- System with vertical toothed belt
- Newly developed V4 control unit
- available at market launch with our basic version
- ideal for single doors with fixed panel or pocket solution
- Can be used on the left and right
- Advantage for large quantities - stock keeping
- Attractive basic price
- Wifi and keypad integrated

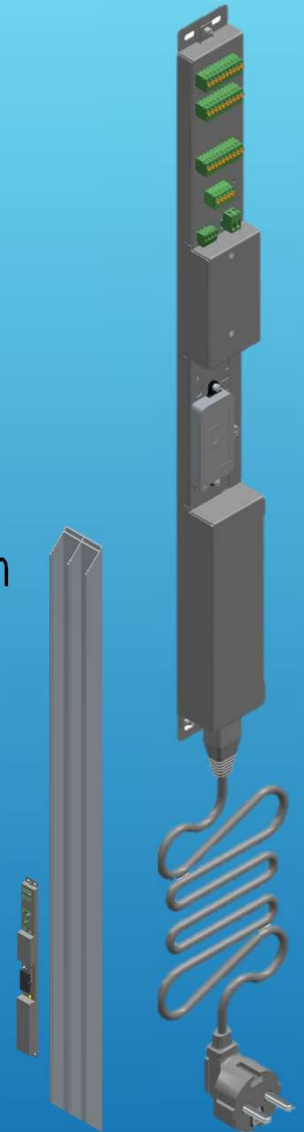

Slim Line - space requirement

- Height
 - Space requirement from the top edge of the door leaf is reduced from 100 mm to 76 mm
- Width
 - Construction width decreases to 51 mm

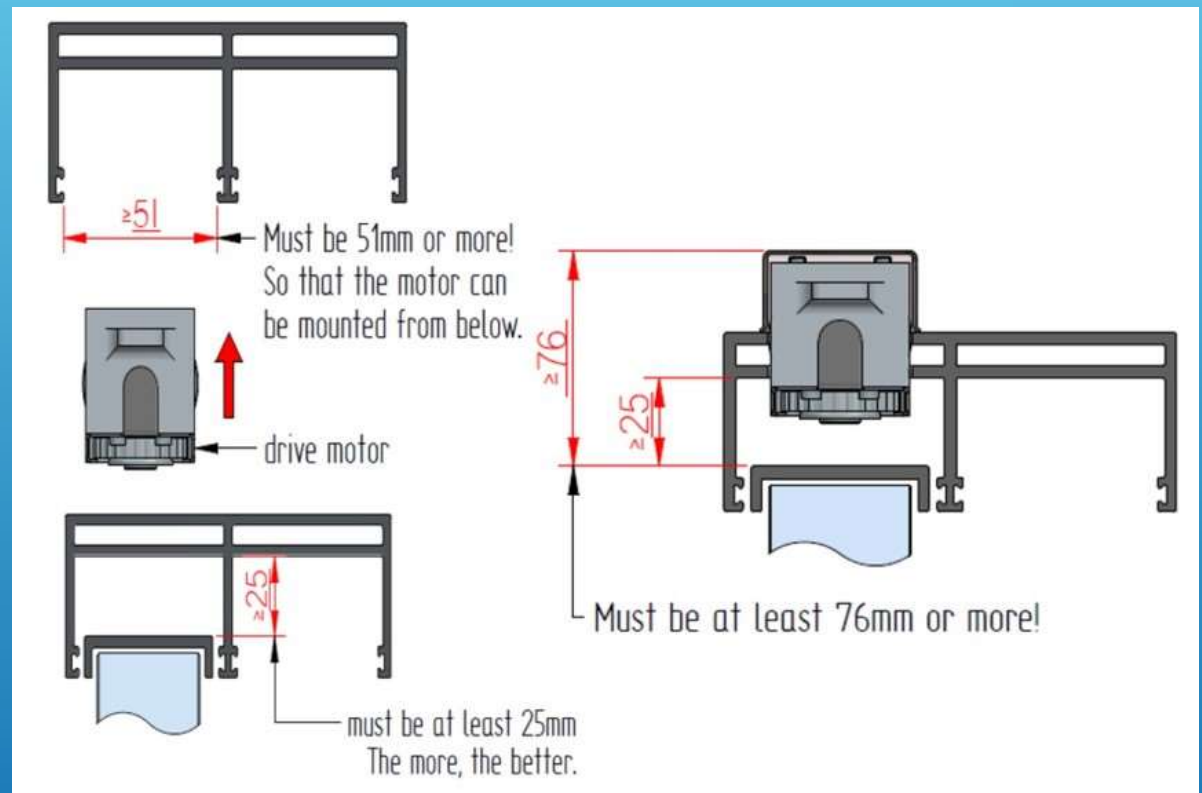

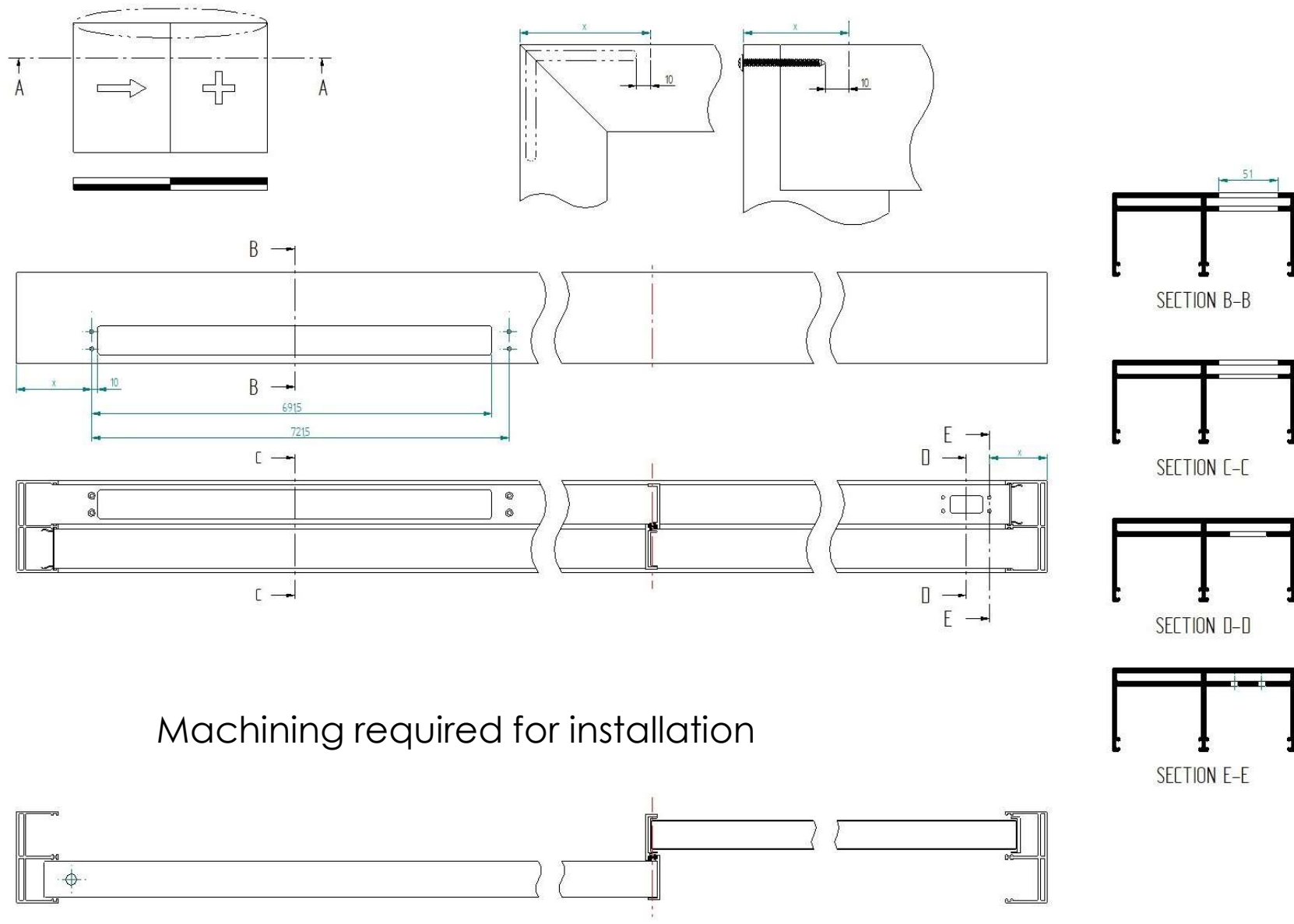

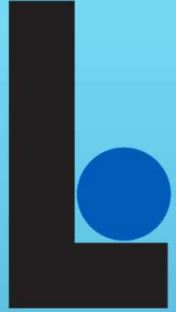

Version with mechanical lock

- Magnetic lock
 - not required Possible cost saving
- “Locked” message
 - is sent to the control unit
- Emergency release
 - not required, can be unlocked by pulling on the belt

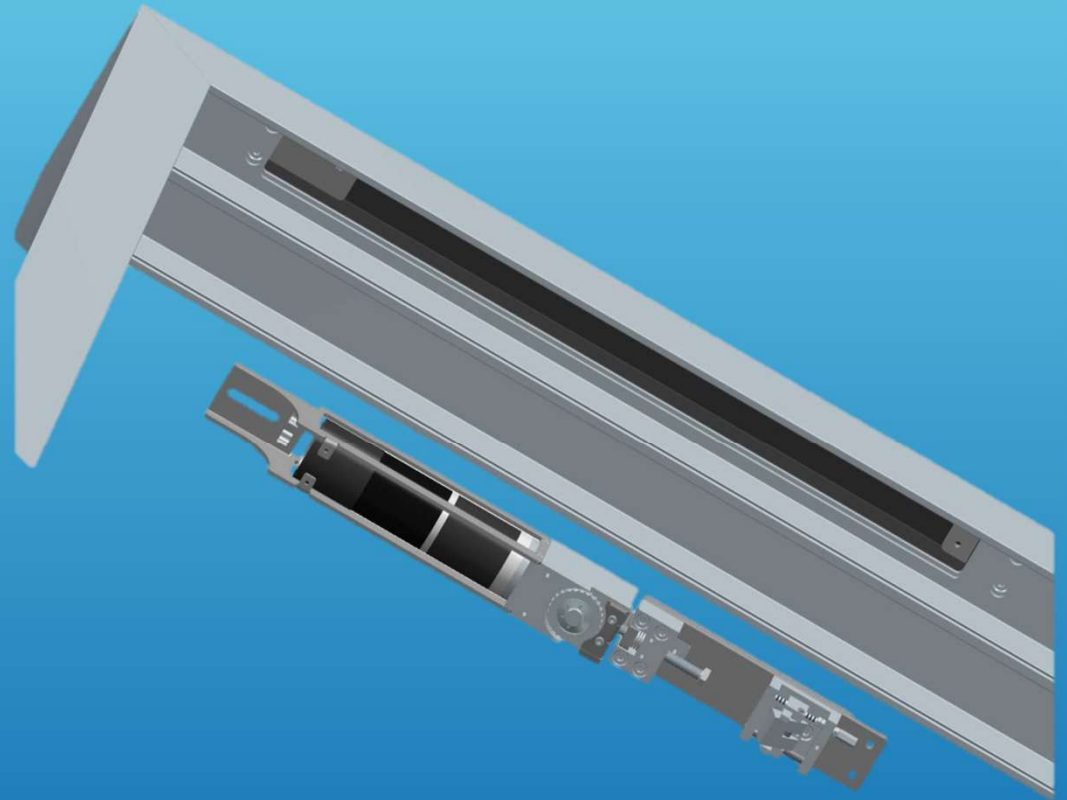

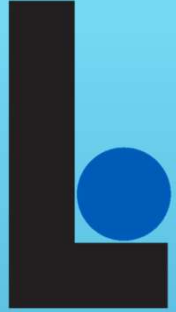

Version with magnetic lock

- Magnetic lock still available on request
 - May be necessary for external doors

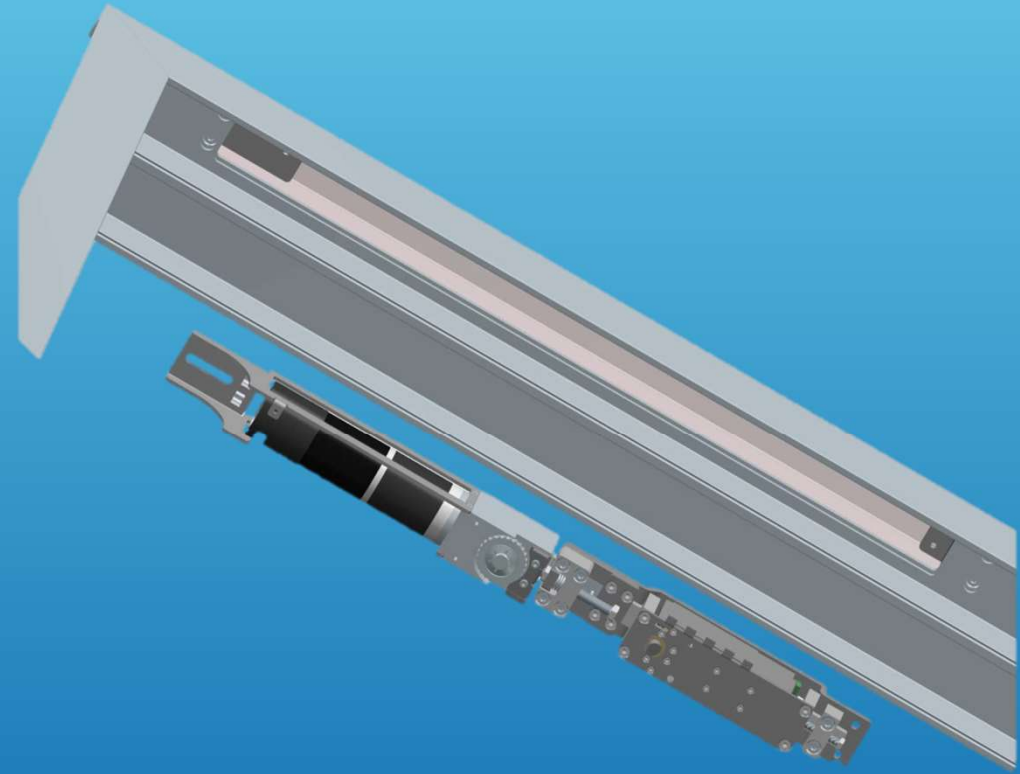



Liberda Antriebstechnik

